

## Design and Development of Solar Cooker Cum Dryer

F.G.SAYYAD<sup>1\*</sup>, N.R. SARDAR<sup>1</sup>, J.P.RATHOD<sup>2</sup>, U.A.BARIA<sup>2</sup>,  
B.K.YADUVANSHI<sup>2</sup>, B.P.SOLANKI<sup>2</sup> and J.J.CHAVIDA<sup>3</sup>

Anand Agricultural University, Anand, Gujarat, India.

<http://dx.doi.org/10.12944/CWE.10.3.30>

(Received: September 03, 2015; Accepted: November 01, 2015)

### ABSTRACT

Solar energy represents non-polluting, inexhaustible renewable source of energy that can be utilized economically to supply man's needs for all the time. A solar cooker cum dryer was designed, developed and fabricated. The performance evaluation of the system was carried out. The solar cooker was used as the solar collector for the solar dryer. A solar cooker having size 750mm x 600mm x 150mm has been developed. The solar dryer was designed with 0.49 m<sup>2</sup> collector area. The collector angle was calculated for Jalgaon and it is 24.16° facing south. Drying chamber of size 750mm x 600mm x 450mm was designed and fabricated. This equipment was tested for cooking of food materials. The various atmospheric and drying parameters were also observed during the testing.

**Key word:** Solar Energy, Solar Intensity, HUF, COP, Drying efficiency.

### INTRODUCTION

Solar energy has been continued to utilize by various countries since 1900's. In the present era a variety of the techniques are there, to utilize solar energy in various aspects of households and commercial sectors. Cooking, water heating, desalination, power generation, heating and cooling of buildings, even lightening now can be operated on solar energy in different households and commercial sectors worldwide<sup>11</sup>. This energy is radiated from the sun in all directions and a very small fraction of it reaches the earth.

Majid Ezzati *et al.* reported that by using solar energy we can save a huge amount of various fuels and capital. Beside this, solar energy is a clean fuel and due to combustion free, it is non polluting fuel too. We not only save the money and fuels but also can maintain a good health by using it and keep away from various harmful diseases which are generated by the burning of biomass<sup>7</sup>.

Cooking is most energy intensive activity in domestic sector increasing demand for energy, unchecked deforestation, drudgery in fuel wood collection and exponential population growth has aggravated cooking energy problems. In this critical situation, solar energy offers practical solution to the household energy problems.

Traditional practice of drying agricultural produce in the field's country yards and the roads by direct exposure to sunshine involves the risk of weather damage, losses in fields and losses during storage and transportation due to improper and incomplete drying. As compared with sun drying, solar dryers can generate higher air temperature and consequences lower relative humidity's they are both conducive to improved drying rates and lower final moisture contents of the agricultural produce.

Cooking of the food requires tremendous amount of energy in the form of fuel, wood, cow dung, crop wastes etc. affecting the environment.

Due to multiple cropping system and increased crop intensity drying of crop also assumed importance on small scale, village women and housewives in urban area needs to cook food and dry food materials.

The present study was undertaken to develop a solar dryer cum cooker with locally available material and simple to operate.

The sun gives  $3.7 \times 10^{26}$  watts energy of which earth intercepts only  $1.8 \times 10^{17}$  watts. This means that the energy emitted by the sun within three minutes is equivalent to the world energy consumption during year. The 99 % of the energy of the solar radiation is contained in the wavelength band from 0.15 to 4 micrometer comprising the near ultraviolet, visible and near infrared region of solar spectrum. The solar constant has a value of  $1.36 \text{ kw/m}^2$  or  $1.95 \text{ cal/cm}^2/\text{min}^9$

The power from the sun intercepted by the earth is approximately  $1.8 \times 10^{11}$  MW, which is many thousands of time larger than the present consumption rate on the of all commercial energy sources. In a tropical counties like India where the sun shine with brilliance for more than 300 days in the year and where solar radiation is as much as 650 calories per sq. cm per day, the utilization of solar energy can be very effective.

Department of Rural Engineering, Gujarat, conducted research on the performance of commercially available box type Jyoti solar cooker and it was evaluated with respect to inside cooker temperature and cooker temperature for three insulating materials namely, fiber glass, saw dust and Aak floss mixed with paddy husk ash were measured. Modifications were made to increase the effectiveness of absorbing surface and to make cooker airtight. The maximum temperature in cooker was recorded for the insulation of Aak floss mixed with paddy husk ash<sup>10</sup>

A box type solar cooker in the agricultural tools Research center, Suruchi campus, Bardoli. It consisted of a double box with double glass cover. The temperature inside the cooker rose to  $90^\circ\text{C}$  in winter and  $105^\circ\text{C}$  in summer<sup>2</sup>

The fire types of solar cookers and their comparative performance was tested in the Central Arid Zone Research Institute, Jodhpur. These are conventional box type solar cooker, conventional solar oven solar stream cooker, parboiled (NPL) type and step reflector type. The temperature in the first type of cooker reached  $178^\circ\text{C}$  in summer and  $148^\circ\text{C}$  in winter<sup>5</sup>

Designed and develops a solar oven providing theoretical concentration of solar energy in the Mechanical Engineering Department, Punjab Agricultural University Ludhiana., Baking and cooking various foods tested the solar oven. It took about 2 hours about cooking red beans and 35 minutes for rice<sup>1</sup>

Tested an inclined dryer to compute maximum radiation throughout the year. They reported that the drying time for chilling in this dryer is reduced to 40% compared to simple cabinet dryer. Moisture content of chilies can be reduced from 82 % to 7.2 % within 5 to 6 days Maximum temperature  $29.3^\circ\text{C}$ . The efficiency of utilization of solar energy was about 13 % in this dryer<sup>8</sup>

Bahai International Community Institute used solar box cooker for its own cooking and later two Scheffler type reflectors with thermal heat storage capability. Many women were attracted, and therefore the next phase did the institute serve placing household size parabolics in village<sup>3</sup>

The basic design consists of a rectangular container, preferably insulated and covered with a roof or clear plastics. There are holes in the base and upper parts of the cabinet and rear panels. The interior of the cabinet was blackened to act as a solar absorber. Perforated drying trays are positioned within the cabinet<sup>4</sup>

The solar dryers have been classified on the following criteria.

1. Whether or not the drying product is exposed to isolation
2. The mode of airflow through dryer
3. The temperature of drying airflow circulated to drying chamber

The main factors governing the choice of the solar collector type is the temperature increase required. Some general guidelines to this choice are as follows:

1. For temperature rise up to approximately 10°C a bare plate solar collector is most suitable due to its simplicity. It is recommended that a higher air velocity be used for bare plate collectors than for collectors with cover plate
2. For greater temperature rise of up to approximately 35°C single cover plate collectors are more effective overall than double or triple covers.

N. Kumar *et al.* has been designed a truncated pyramid type solar cooker. It was designed for multipurpose owing the geometry of design rays hitting inside the cooker (walls) were reflected with high intensity to downwards a higher temperature was maintained at the absorber tray (bottom side). By making an increment in the depth of the cooker the device acts as a dryer for the domestic or homely purpose<sup>6</sup>.

The cooker was single glazed with a pane of 2 mm thickness float glass as well as the whole system was i.e. MSES. The inner absorber tray was designed particularly for good sensible heat storage and a rubber gasket of 1.5 mm thickness was placed in opening lid to make leak proof. Apart this, a high intensity planar reflector, 184 × 75 cm<sup>2</sup> of corrugated lacquered aluminium was used to enhance the efficiency of the combined components of the system. The system was placed towards the south orientation<sup>12</sup>

**Absorber Performance**

Desirable properties of absorber in the solar collector are high absorptivity of incident radiation, low emissivity, good thermal conductivity, steadiness at the temperature encountered, robustness, low cost, low weight per unit area.

Where

Q = Latitude at test site, Q = 21.75°N

Positive value of b = collector should be south facing.

Negative value of b = Collector should be North facing.

$$\beta = (21.75 - (-2.41)) = 24.16^\circ$$

As the value of b is + 21.75°, collector should be south facing at an angle of 21.75°

**MATERIALS AND METHODS**

The solar cooker cum dryer was Designed and fabricated in the Department of Agricultural Process Engineering, Jalgaon,

**Design of solar collector**

The solar collector is to be designed by following assumptions:

1. The dryer is situated at latitude of 21.05°N.
2. Average isolation on horizontal plane during March is 580 w/m<sup>2</sup>.

**Slope of The Collector (β)**

In order to calculate the optimum slope of the collector, march 16 was taken as mid point of the drying season.

Angle of inclination (φ)

$$\delta = 23.45 \sin (0.9863 (284 + n)) \dots(1)$$

For March 16, n = 75

$$\delta = 23.45 \sin (0.9863(284 + 75)) \dots(2)$$

$$\delta = -2.41$$

Slope of the collector (b) was calculated by following formula,

$$\beta = (\phi - \delta) \dots(3)$$

w = It is the hour angle, is the angular displacement at the sun east or west. It is zero at solar noon and changes 15° per hour. Morning is negative and afternoon is positive.

w = 0 is used for present calculation.

The intensity of radiation on horizontal surface θ<sub>h</sub> was calculated as follows:

Since slope is zero, equation (3.3) is simplified as

$$\cos \theta_h = \sin \delta \sin \phi + \cos \delta \cdot \cos \phi \dots(4)$$

$$= \sin(-2.41) \cdot \sin(21.75) + \cos(-2.41) \cdot \cos(21.75)$$

$$= 0.912$$

The equation (3) was used again to calculate the angle of incidence upon collector surface

$$\begin{aligned} \cos\theta &= \sin(-2.41)\sin(21.75)\cos(24.16) - \sin(-2.41) \\ &\cos(21.75)\sin(24.16)\cos 0 + \cos(-2.41)\cos(21.75) \\ &\cos(24.16)\cos 0 + \cos(2.4)\sin(21.75)\sin(24.16) \\ &\cos(0)\cos(0) \\ &= 0.8484 + 0.1515 \\ \cos\theta &= 1.00 \end{aligned}$$

The intensity of insolation on collector surface  $I_c$

$$I_c = I_h (\cos \phi / \cos \theta) \quad \dots(5)$$

Where,  $I_h$  = Intensity of insolation of horizontal surface,  $W/m^2$

$$I_c = 580(1.00/0.912)$$

$$I_c = 635.96 \text{ W/m}^2$$

**Intensity of insolation on collector surface ( $I_c$ )**

Instantaneous insolation on surface is approximately proportional to the cosine of the angle of incidence ( $\theta$ ).

**Table 1: Dry bulb Temperatures variations during the day**

Sr. no.	Day Time	DBT of ambient air °C $t_a$
1	10.00	32
2	11.00	32
3	12.00	32
4	1.00	33
5	2.00	33
6	3.00	33
7	4.00	32
8	5.00	32

**Table 2: Relative humidity variation during day**

Sr. no.	Sun Hours	Relative Humidity (%)
1	10	55
2	11	53
3	12	47
4	13	45
5	14	43
6	15	43
7	16	43

The angle of incidence on a south-facing roof at midday following equation was used to calculate the angle of incidence for insulation falling on a surface (Brenderfor et al 1985)

$$\begin{aligned} \cos\delta &= \sin\delta \cdot \sin Q \cdot \cos\beta - \sin\delta \cdot \cos Q \cdot \sin\beta \\ \cos r &+ \cos\delta \cdot \cos Q \cdot \cos\beta \cdot \cos w + \cos\delta \cdot \sin Q \cdot \sin\beta \cdot \cos w \\ &+ \cos\delta \cdot \sin\beta \cdot \cos w + \cos\delta \cdot \sin\beta \cdot \sin r \cdot \sin w. \end{aligned}$$

Where

$\delta$  = Angle of incidence  $-2.41$

$Q$  = Latitude of test site  $21.45^\circ N$

$\beta$  = Slope of collector  $24.16^\circ$

$r$  = surface azimuth angle, for this can be considered it's orientation with respect to a north south axis. The angle varies from  $-\pi + \pi$  zero is due to south, east is negative and west positive.

The value of  $r = 0$  was used for the present calculation.

**Collector area ( $A_c$ )**

The collector area was designed to dry a batch of 0.5kg fresh potato chips. The initial moisture content of potato was 77.5% (wb). The potato chips were dried up to 6.5%. the heat required to drr the potato was calculated by using heat balance equation. The procedure is described given below:

Water present in the potato =  $0.5 \times 0.755 = 0.3875 \text{ kg}$   
 Weight of dry matter present =  $0.5 - 0.3875 = 0.1125 \text{ kg}$   
 Weight of final product =  $0.1125(100/93.05) = 0.12 \text{ kg}$   
 Water to be removed =  $0.5 - 0.12 = 0.38 \text{ kg}$   
 Heat is required to evaporate 0.38 kg of moisture.

**Assumptions**

1. Specific heat of potato =  $0.42 \times 4.186 = 1.758 \text{ KJ/Kg}$

**Table 3: Solar intensity variation during day**

Sr. no.	Sun Hours	Solar intensity
1	10	75
2	11	80
3	12	90
4	13	96
5	14	90
6	15	80
7	16	75

- 2. Latent heat of vaporization of water = 2280 KJ/Kg
  - 3. Drying temperature = 60°C
- Heat Balance = Sensible heat + Latent heat  
 = 0.5 x 1.758 x 35 + 0.38 x 2280  
 = 897.165 KJ

Therefore heat energy required to dry 0.5 kg of fresh potato from 77.5 % to 6.5 % moisture content (wb) is 897.165 KJ

Heat energy available = 625 W/m<sup>2</sup>/hr

**Assumptions**

- 1. 0.5 Kg fresh potato requires 7 hrs to dry to 6.5% moisture content.
- 2. Collection efficiency (*nc*) of the collector including total losses 12 %

Area of collector = Heat required / Heat available x *nc*  
 = 897.165 / 15750 x 0.12  
 = 0.475 m<sup>2</sup>

For safe design effective collector area of 0.49 m<sup>2</sup> was considered

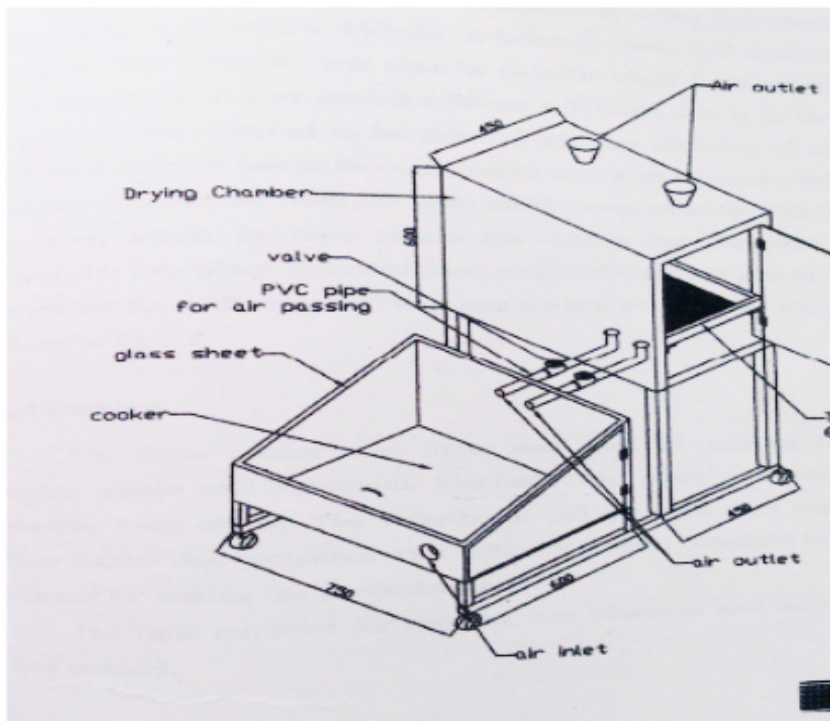

Fig. 1: Design of solar cooker cum dryer

Table 4: HUF and COP of the dryer on an average drying day

Day Time	Dry Bulb Temp. of Ambient Air °C ( <i>t</i> <sub>0</sub> )	Dry Bulb Temp. of Ambient Air °C ( <i>t</i> <sub>1</sub> )	Dry Bulb Temp. of Exhaust Air °C ( <i>t</i> <sub>2</sub> )	<i>t</i> <sub>1</sub> - <i>t</i> <sub>2</sub>	<i>t</i> <sub>1</sub> - <i>t</i> <sub>0</sub>	<i>t</i> <sub>2</sub> - <i>t</i> <sub>0</sub>	H U F <i>t</i> <sub>1</sub> - <i>t</i> <sub>2</sub> / <i>t</i> <sub>1</sub> - <i>t</i> <sub>0</sub>	COP <i>t</i> <sub>2</sub> - <i>t</i> <sub>0</sub> / <i>t</i> <sub>1</sub> - <i>t</i> <sub>0</sub>
10	32	39	35	4	7	3	0.57	0.43
11	32	43	40	3	11	8	0.27	0.73
12	32	60	55	5	28	23	0.18	0.82
13	33	60	56	4	27	23	0.15	0.85
14	33	52	48	4	19	15	0.21	0.79

**Drying Chamber**

The drying chamber size is fixed as 750mm X 600mm X 450mm and perforated wire mesh tray of size 650mm X 370mm is to be provided inside the drying chamber. A plenum chamber of size 750mm X 450mm X 150mm is to be provided with the drying tray for air circulation. Drying chamber size is to be designed by considering thin layer drying.

**Air Circulation System**

Two pipes of size 25mm are to be extended from solar cooker or solar collector to the bottom of drying chamber. These pipes will be the hot air inlets to the dryer. They will be provided with valves of size 25mm to control the air flow rate. Three inlet holes will be provided on the sides of cooker with caps.

**Fabrication of the cooker**

The cooker will be fabricated by using wood, hard board, insulation material, G.I. sheet etc.

**Frame**

Wooden frame of size 750mm x 600mm will be made using wood strips of size 50mm x 50mm. While fabricating the frame, the collector angle will be adjusted by providing slope of 21.75° to the wooden strips.

**Solar Cooker**

A cooker box will be fabricated by fitting hardboard (5mm thick) from the outside and G.I. sheet (24SWG) from inside the cooker box. Coir mat (30mm thick) will be fitted in between hardboard and G.I. sheets as an insulating material to prevent the heat loss. Using plain glass having 3mm thickness covered the sloping portion of the box. The sheet was painted black by using black mat paint enough room was provided for cooking utensil in the cooker box. Four cooking utensils made of aluminum can be placed. The diameter and height of each utensil were 200mm and 62.5mm respectively. Box is provided

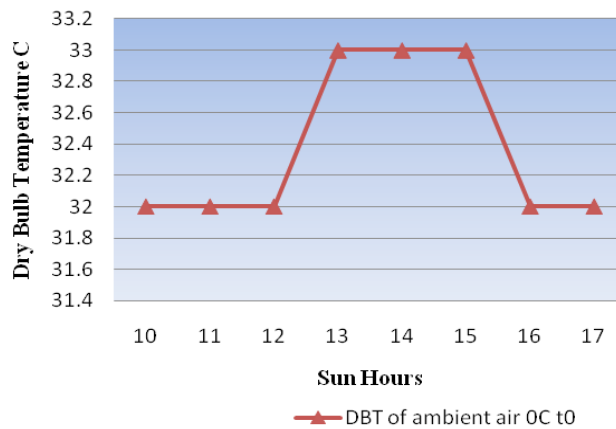

**Fig.2: Dry bulb temperature variation during the day**

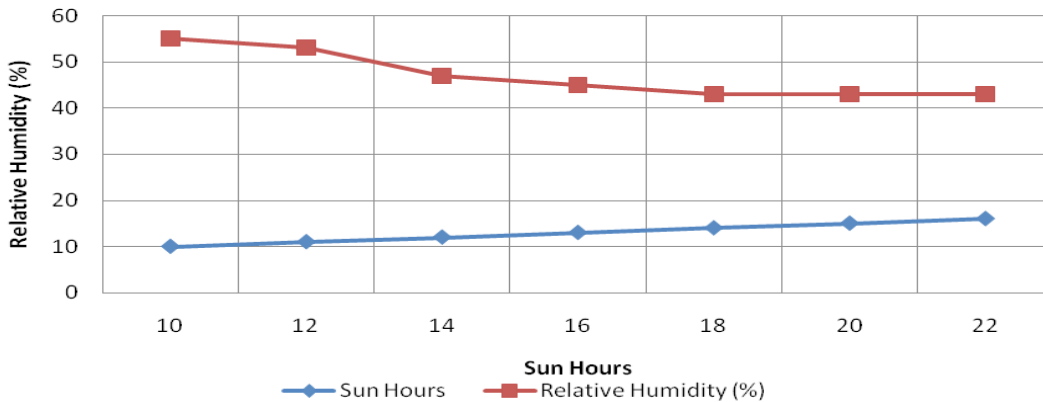

**Fig.3: Relative humidity variation during the day**

with door of placing the utensils. Three holes were provided on the cooker box with caps of air inlet two PVC pipes (25mm) were extended from the back side of box for hot air outlet to the drying chamber.

**Fabrication of drying chamber**

The drying chamber will be fabricated by using G.I. sheet (24SWG) of size 750mm x 600mm x 450mm. A wooden frame will support the drying chamber. The chamber will also be painted black from outside to receive solar insulation. A tray having 650mm x 370mm size is to be provided for supporting the material to be dried. A plenum chamber of size 750mm x 450mm x 150mm has to be constructed and is to be connected to the solar collector. The hot air from the solar cooker cum collector enters the plenum chamber, which in turn enters the drying the chamber through the materials. Two pipes extended from solar collector are provided with valves to control the airflow rate. Two pipes outlets were for the exhaust of air as shown in fig 1.

**Parameter to Study**

Temperature: temperature will be measured by using mercury in glass thermometer (0-110°C). Dry bulb temperature and wet bulb temperature of ambient air will be measured. The air temperature inside the cooker and inside the drying chamber is to be measured.

Solar Intensity: Solar Intensity is to be measured by using a solar –intensity meter known as ‘Suryamapi’ (make- Central Electronics Ltd., SM-203 Range- 0-120 mW/cm<sup>2</sup>). The solar intensity is

to be measured at predetermined intervals during cooking and drying experiments.

Drying Efficiency (nd): It is the ratio of energy required to evaporate the moisture to the energy supplied to the dryer. Drying efficiency is calculated by following formula (Brenidorfer et. Al) 1985

$$d = \frac{w\Delta H_1}{I_c A_c} \times 100 \quad \dots (6)$$

Where,

- w = Mass of moisture evaporated (kg) in time ‘t’.
- ΔH1 = Latent heat of evaporation (KJ/Kg)
- Ic = Isolations on collector surface, (KW/m<sup>2</sup>)
- Ac = collector area, m<sup>2</sup>

**Heat Utilization Factor (HUF)**

This is defined as the ratio of temperature decrease due to cooling air during drying and the temperature increase due to heating of air (Brenidorfer et. al 1985).

HUF is calculated by formula as

$$HUF = (t_1 - t_2)/(t_1 - t_0)$$

Where;

- t<sub>0</sub> = Dry bulb temperature of a ambient air
- t<sub>1</sub> = Dry temperature of drying air
- t<sub>2</sub> = Dry bulb temperature of exhaust air

**Coefficient of Performance**

It is calculated by as follows,

$$COP = (t_2 - t_0) / (t_1 - t_0)$$

Where,

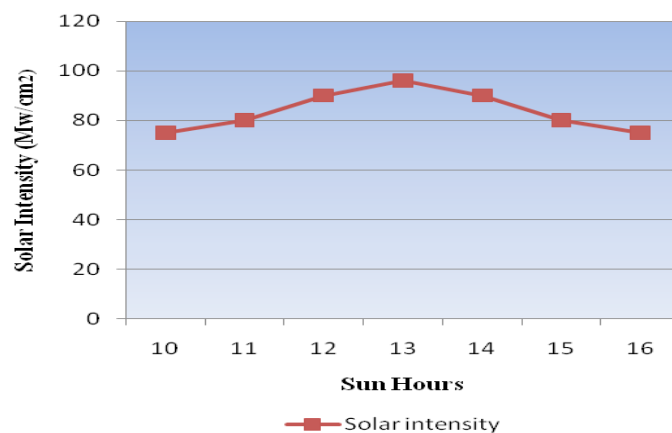

**Fig.4: Solar intensity variation during the day**

$t_0$ ,  $t_1$ , and  $t_2$  have the same meaning as mentioned above.

$$\text{HUF} + \text{COP} = 1$$

### Measurement of Atmospheric Parameters

#### Dry Bulb Temperature

The dry bulb temp gradually increased from 10 o'clock until about 13 hrs latter it started decreasing (Fig.2)

#### Relative Humidity

The daily variation in the Relative Humidity is shown in fig 4.2. The Relative Humidity was high (55%) at 10 o'clock and it was decreased up to 13 hrs (about 42 %). Thereafter it started increasing. (Fig.3)

#### Solar Intensity

The variation in the solar intensity during the testing period is shown in Fig 4. Solar Intensity increased with day time and it reached the peak at 13 hrs. The maximum intensity observed was 98 mW/cm<sup>2</sup> at 13 hrs and the minimum was 84 mW/cm<sup>2</sup> at 15 hrs.

### Performance characteristics of solar cooker cum dryer

Performance characteristics of Solar cooker cum dryer like heat utilization factor, coefficient of performance (COP) and drying efficiency were calculated and are discussed as follows.

#### Heat utilization factor (HUF)

The heat utilization factor of the dryer was calculated and is shown in table 4. It is seen from table that the heat utilization factor was high at the

time of beginning of drying operation. The maximum heat utilization factor is 0.57 & minimum is 0.10. Similarly the COP was also calculated and presented table 4. The maximum COP was 0.80 & minimum was 0.43. The COP was minimum at commencement of drying and maximum at the closing stages of drying. The total of heat utilization factor & coefficient of performance is 1.

#### Drying efficiency

The drying efficiency of the Solar cooker cum dryer was calculated by using the equation given in section .It was observed that the efficiency of the dryer was high at the beginning that is 11.4 % and minimum at the time of completion of drying that is 0.7%.

### CONCLUSION

The solar cooker cum dryer was designed and fabricated for cooking and drying of food materials. The solar cooker used as solar for drying operation. A solar collector of the size of 0.49 m<sup>2</sup> was designed along with separate drying chamber. Inlet and outlet holes were provided for exhaust air. Two PVC pipes with valves were provided for carrying hot air to drying chamber. While working as cooker, the holes and valves were closed and during drying operation they were opened. On the basis of the findings of investigation following conclusions were drawn. Solar intensity on collector surface was about 8 to 10 % more than that of horizontal surface. The average heat utilization factor and coefficient of performance of the dryer were 0.2 and 0.8 respectively. Solar cooker could be effectively used as dryer.

### REFERENCES

1. Anon. Research Progress Report of Mechanical Engineering, Department of Punjab Agricultural University, Ludhiana, Proceedings of the seventh meeting of all India solar energy working Group held at P.A.U. Ludhiana November, 2013-14 pp 11-12
2. Anonymous. Solar Cooker Box Type. Directory of Solar Energy Projects in India. Compiled By Tata Energy Research Institute, New Delhi, (1978).
3. Bahai International Community Institute used solar box cooker for it's own cooking and later two scheffier type reflector with internal heat storage capability. The programmes of the institute have received recognition from UNESCO, (2002).
4. Brenidorfer B and other, Solar dryers: their role in post harvest processing, Commonwealth Secretariat. Marlborough house, London, (1985).
5. Garg, H.P. Progress Report on Solar Energy



- Utilization at central Arid Zone Research Institute, Jodhpur. Proceedings of the Seventh Meeting of All India Solar Energy Working Group, held at P.A.U. Ludhiana. 13-14, pp. 11-12.
6. Kumar Naveen, Agravat S, Chavda TV, Mistry H.N, "Design and development of efficient multipurpose domestic solar cookers/dryers", *Renewable Energy*, **33**: pp. 2207-2211 (2008).
  7. MajidEzzati, Alan D. Lopez, Anthony Rodgers, Stephen Vander Hoorn, Christopher J.L. Murray, and the Comparative Risk Assessment Collaborating Group, "Selected major risk factors and global and regional burden of disease", *the lancet*, **360**: pp. 1347-1360 (2002).
  8. Pande P.C. and Thanvi, K.P., Development of inclined solar dryer with alternate materials. Renewable energy and environment. Proceedings of the national solar energy convection. Udaipur, India, 1-3, 41-45 (1982).
  9. Ranjeet Singh and O.P. Yadav. Design and testing of parboiled surface concentrated type of solar cooker. Renewable Energy and Environment. Proceeding of National Solar Energy Convention, Udaipur. India. 1-3. 63 (1989).
  10. Rawal, S.R. and A.C. Varshneya. Evaluation and modification of box type solar cooker. Department of Rural Engineering, college of Agriculture. Sardar Krishinagar, Gujrat, (1984)
  11. SoterisKalogirou, "Solar Energy Engineering: Processes and Systems", published by Elsevier's Science and Technology, Rights Department in Oxford, UK, (2009).
  12. Wei Sheng-Xian, Li Ming, Zhou Xi-Zheng, "A theoretical study on area compensation for non-directly-south-facing solar collectors", *Applied Thermal Engineering*, **27**: pp. 442-449 (2007).